



BUILDER AND DEVELOPER INFORMATION PACKET

for the use and installation of

CLUSTER BOX UNITS (CBU's) 4C Style Central Boxes



**TENNESSEE DISTRICT
NASHVILLE, TN 37229**

TO: Project Developers / Builders / Local Government Offices

RE: Mode of Delivery

During the development stage of a new subdivision, it is the responsibility of the developer and/or builder to pay the costs necessary to bring streets, sidewalks, water, phone, gas, and electric service into a new development. Like utility companies, the Postal Service is a service-based organization. We provide the service of mail delivery; however, we do not provide the mail receptacle.

It is the policy of the U. S. Postal Service that mail delivery to all new developments is centralized delivery, most often using cluster box units (CBU). In the Tennessee District, as in other parts of the country, it is the responsibility of the customer (developers and builders) to provide the necessary mail receptacle equipment.

The authority for this is from the Postal Operations Manual (POM).

632.1 Customer Obligation

632.11 Responsibilities

Appropriate mail receptacles must be provided for the receipt of mail. The type of mail receptacle depends on the mode of delivery in place. Purchase, installation, and maintenance of mail receptacles are the responsibility of the customer.

631.1 General

The Postal Service-approved modes of delivery available for all existing delivery points, newly established and extensions of delivery points, are described in 631.2. Centralized delivery is the Postal Service's preferred mode of delivery for all new residential and commercial developments. Curbside, sidewalk delivery and door modes are generally not available for new delivery points, with very rare exceptions as determined by the Postal Service in its sole discretion on a case-by-case basis.

631.241 General

Newly established or extended business or residential customers must request and receive approval of the delivery location and mode of delivery from the local Postmaster or District designees. These deliveries will not receive mail delivery service until the mail receptacles are installed and the units and locations are approved by local postal management. Options and requirements for modes of delivery are directed by the Postal Service.

631 .242 Newly Established or Extended Centralized Delivery Points (Preferred Mode)

Centralized delivery is the preferred mode for new or extended business or residential delivery points, with very rare exceptions as determined by the Postal Service in its sole discretion on a case-by-case basis: see 631.1. The mail receptacle and location of the delivery point(s) are approved by local postal officials in advance of the occupancy of the residence, business, or other site associated with the delivery point.

The POM also advises that appropriate locations for installation be verified and approved by the Postal Service and local government.

To facilitate the most cost-effective delivery of mail into the 21st century, I am committed to assisting all customers, both large developers and individual customers, with references for the purchase, installation, and maintenance of authorized mail receptacle equipment.

Please contact me prior to any new development or renovation and I will be happy to assist you in regards to approved mode of delivery, mail receptacles, and appropriate delivery locations.

Sincerely,

Amanda Douglas
Address Management Manager
District Growth Management Coordinator
Tennessee District
United States Postal Service
PH: (615) 872-5660

What is a customer's personal identity and security worth?

Is it worth more than the perceived convenience of a walk to the end of the driveway?

The U. S. Postal Service (USPS) in the Tennessee District recognizes that our number one responsibility is to our customers. The consumer that purchases a home is our customer, as is the developer and the builder providing the house. As a federal agency, the mission of the USPS is to accept, transport, protect and deliver the mail for the citizens of the United States of America. We are asking you, the developers and builders, to assist us in protecting our nation's citizens.

Identity thieves target all economic areas, looking for easy targets from which to steal. Unsecured curbside mailboxes are frequently their target of choice. Thieves may be after Social Security checks, income tax refunds, public assistance checks, credit cards, credit card convenience checks, or other valuables. For example, the financial information contained on a bank statement could enable a thief to order blank checks on a checking account. The best defense in preventing this type of crime is in securing the mail. Cluster box units (CBU) are the least expensive and most effective method for combating mail theft.

The US Postal Service recognizes the convenience of a mailbox located at the end of a customer's driveway. However, should a customer be the victim of mail theft, the time, money, aggravation, and efforts needed to rectify the damage can be extremely costly and inconvenient. To insure security of the mail, we strongly suggest the use of centralized, secure cluster box units (CBU's).

Although the USPS is a federal agency, we do not receive government funding. We are a self-supporting entity supported only through stamp sales and services. If mail theft and/or identity theft occur from an unprotected curbside mailbox when a secure CBU could have been in use, the USPS must direct our own resources (postal inspectors) and often those of local law enforcement agencies, as well, to investigate the situation. Unfortunately, resolution and restitution are not always the outcome.

The USPS wants to protect the nation's mail and the identity of its citizens in the safest and most cost efficient way possible. Long after you, the developers and builders, move on to develop your next neighborhood, the USPS remains in the community serving American citizens.

Curbside mailboxes lining the street are an easy target for vandalism and theft.



Over time and without frequent maintenance, curbside receptacles can become an eye sore.



A Sensible Approach for the Use of **CLUSTER BOX UNITS** (CBU)

Long after the builder has sold their home to a buyer, the United States Postal Service (USPS) will remain as a neighborhood fixture providing responsive service to the nation's citizens—our customers. We must consider what is in the best interest of all the citizens we serve—taking into consideration both current and future costs.



Dog Bites — Dogs are very territorial animals. Minimizing trips onto a Postal customer's property reduces the possibility of dog bites.

Community Gathering Area — Cluster box units (CBU) are a location for neighbors to encounter one another and stay acquainted.



Neighborhood Watch — Coupled with their side benefit as a community gathering area, CBU's offer a centralized focal point for added neighborhood watch security.



Unnecessary Trips to the Post Office — Postal regulations dictate that no item can be left at a location that is insecure or does not have a mail receptacle able to accommodate its size, unless the customer has agreed to accept responsibility for its safety. With the use of CBU's, carriers are now able to deliver and secure most items (books, photos, parcels, etc.), rather than leaving notices. Should an individual be away from home (especially, unexpectedly) for several days, their mail does not need to be placed on hold. It can accumulate in a secure receptacle without the need to travel, yet again, to the post office.

Reduces Neighborhood Traffic — CBU's eliminate the need for the carrier to pull in and out between parked cars while serving multiple boxes along busy

streets. Most certainly, it reduces the chance that a young child may be encountered and injured as the carrier attends to traffic and avoiding parked vehicles.



Snow Removal — When snow accumulates and restricts access to a curbside box, each homeowner is required to clear a sufficient area to provide drive-up access to the box without the carrier needing to dismount or back his vehicle. With centralized delivery, the homeowners can partner to keep their one CBU clear of snow.



Unsightly Landscaping — Curbside mailboxes can be unsightly elements lining any street (the “picket fence” effect). With proper planning, CBU’s offer a beautiful addition to any planned community and blend into the neighborhood in a subtle way.

Reduces Mail Theft —  Criminals steal mail specifically looking for checks with the intent of “washing them” and rewriting them for their own use. Theft from curbside boxes takes a matter of just seconds. CBU’s offer the security of locked mail receptacles for both incoming and outgoing mail.

Reduces Identity Theft — Identity theft is a very difficult crime to combat. Hundreds of hours and untold frustration is the norm when trying to undo the damage caused by criminals stealing Postal customers’ identities.

Cost —  Per address, CBU’s often cost less than decorative curbside mailboxes. In addition to added security and convenience, CBU’s contribute to enhanced property value and may increase your profit margin.

Replacement Rate — Curbside mailboxes have to be replaced more frequently than CBU’s. Curbside mailboxes are frequently vandalized or may be struck by automobiles, garbage trucks, etc...

Automobile Parking — Parking is less restricted in areas where CBU’s have been installed (one delivery location for a CBU versus up to sixteen individual

locations for curbside boxes). Postal customers do not have to be concerned about parked cars blocking their mailboxes and affecting their daily delivery.



Unexpected Absences — In today's busy world, many of us are called away unexpectedly. Mail can then accumulate in a receptacle, leaving the customer exposed to the criminal element. With the use of CBU's, the mail is secured behind a locked door.



Anonymity — CBU's have customer names and addresses unseen and secure behind locked doors, with access only by Postal Service employees.

CBU Locations — CBU's are conveniently located within walking distance of homes. If time is an issue, the customer can easily stop by on their drive through the neighborhood to or from work.



ADA — CBU's are in compliance with American Disabilities Act regulations

CENTRALIZED DELIVERY/CLUSTER BOX UNITS

ADVANTAGES FOR BUSINESS CUSTOMERS

Like all businesses, the U. S. Postal Service is always looking for new and innovative ways to cut costs in order to operate more efficiently.

Centralized delivery to business customers offers the following advantages:

- The potential for earlier delivery times
- All tenants receive their mail at essentially the same time
- Saves trips to the post office to pick up packages, etc.
- Reduces the need to put mail on “hold” when the business is closed
- Eliminates missed mail delivery in cases when the office is closed or temporarily unmanned
- Permits Saturday delivery to all tenants—open and closed
- Locked boxes offer security and privacy for both incoming and outgoing mail
- There is no unsecured outgoing mail sitting around waiting for the letter carrier’s arrival
- Helps to stabilize postage rates
- Office routines are not interrupted by mail delivery
- Decreases fuel consumption—improving air quality
- Lessens traffic congestion

\$ COST COMPARISON \$

CLUSTER BOX UNITS (CBU)

VS

CURBSIDE MAILBOXES

Many developers and builders are under the misconception that individual curbside mailboxes are less expensive than a Cluster Box Unit (CBU). In fact, this is not the case; rather, one CBU actually costs less than curbside mailboxes. According to an independent contractor as of April 2007, the average installation costs for CBU and curbside mailboxes are as follows.

16-unit CBU with concrete pad = \$1,775.00 (\$110.94 per address)

Curbside mailbox = \$150.00 per address (cost of the mailbox may vary depending on security features and size)

CLUSTER BOX UNIT -- CBU

CBU customers have a locked secure compartment for the delivery of daily incoming mail, a secure collection point for their outgoing mail, and secure built-in lockers for parcels. In addition, CBU's offer customers anonymity for their name and address. Each of these features greatly reduces the potential for mail and identity theft. Typical mounting are shown below.





CURBSIDE MAILBOXES

A curbside mailbox does not offer the same level of security from mail and identity theft that a CBU does. In addition, curbside mailboxes require frequent maintenance and replacement due to damage or destruction (automobile collisions, children hitting them with baseball bats, weathering issues, etc.). In many cases, these mailboxes are not only unsightly but are also unsecured. With a curbside box, there is no place for the carrier to secure parcels—resulting in a trip to the post office so the customer can pick them up.



ADDITIONAL INFORMATION ON CLUSTER BOX UNITS (CBU)

- STANDARD UNITS AVAILABLE -



FCBU Type I
8-box Unit



FCBU Type II
12-box Unit



FCBU Type IV
13-box Unit



Model 1570 (F) CBU

16-Box Unit



Outdoor Parcel Locker

CLUSTER BOX UNITS (CBU) - UPGRADE POSSIBILITIES -

CBU's come in different styles and colors. Custom pedestals are also available.



4C Style Centralized Delivery

Reminder: a minimum of 1 parcel lockers per 10 deliveries is required



CLUSTER BOX UNIT (CBU) **- CONCRETE PAD SPECIFICATIONS -** **-ANCHORING METHODS-**

The following documents are the only USPS approved specifications for pouring concrete pads for the anchoring of CBU's.

CONCRETE SPECIFICATIONS FOR SINGLE UNIT CONCRETE PAD

CONCRETE SPECIFICATIONS FOR MULTIPLE UNIT CONCRETE PAD

ANCHORING METHODS FOR CENTRALIZED BOX UNITS (CBU)

CBU's must be installed approximately one week prior to customer occupancy.

CBU's must not be installed until the local USPS representative has conducted an on-site visit to ensure compliance with the official specifications. **Contact the local USPS representative to have the pads inspected prior to pouring the concrete.**

CBU's must be installed facing the correct direction. CBU's installed on concrete pads poured behind the sidewalk should face the sidewalk. CBU's installed on concrete pads located in landscape strips between the curb and the sidewalk should face the sidewalk. Do not install CBU facing the curb or street—causing the carrier and the customer to stand in the street to deliver or retrieve mail.

CBU's should not be installed so close to an intersection or traffic lane that they block visibility for approaching traffic or could be struck by a passing motor vehicle.

CBU's should not be located on dead-end streets where there is no safe turnaround for Postal delivery vehicles.

Notify your local USPS representative immediately upon completion of the CBU installation so that we can install the arrow lock and secure the unit.

All CBU compartment keys will be distributed by the builder/developer at the time of move in. The Postal Service can agree to distribute the keys if the builder/developer will not be on-site throughout the move in timeframe. The local USPS representative needs to be contacted by the builder/developer for the box address assignments. Each homeowner should be notified by the builder/developer of the approved mode of delivery for the development at the time of move in.

Any deviations from the USPS designated location of the CBU must not occur without first receiving authorization from the local USPS representative.

USPS APPROVED SPECIFICATIONS – CONCRETE PAD (SINGLE UNIT)

(All measurements are in inches)

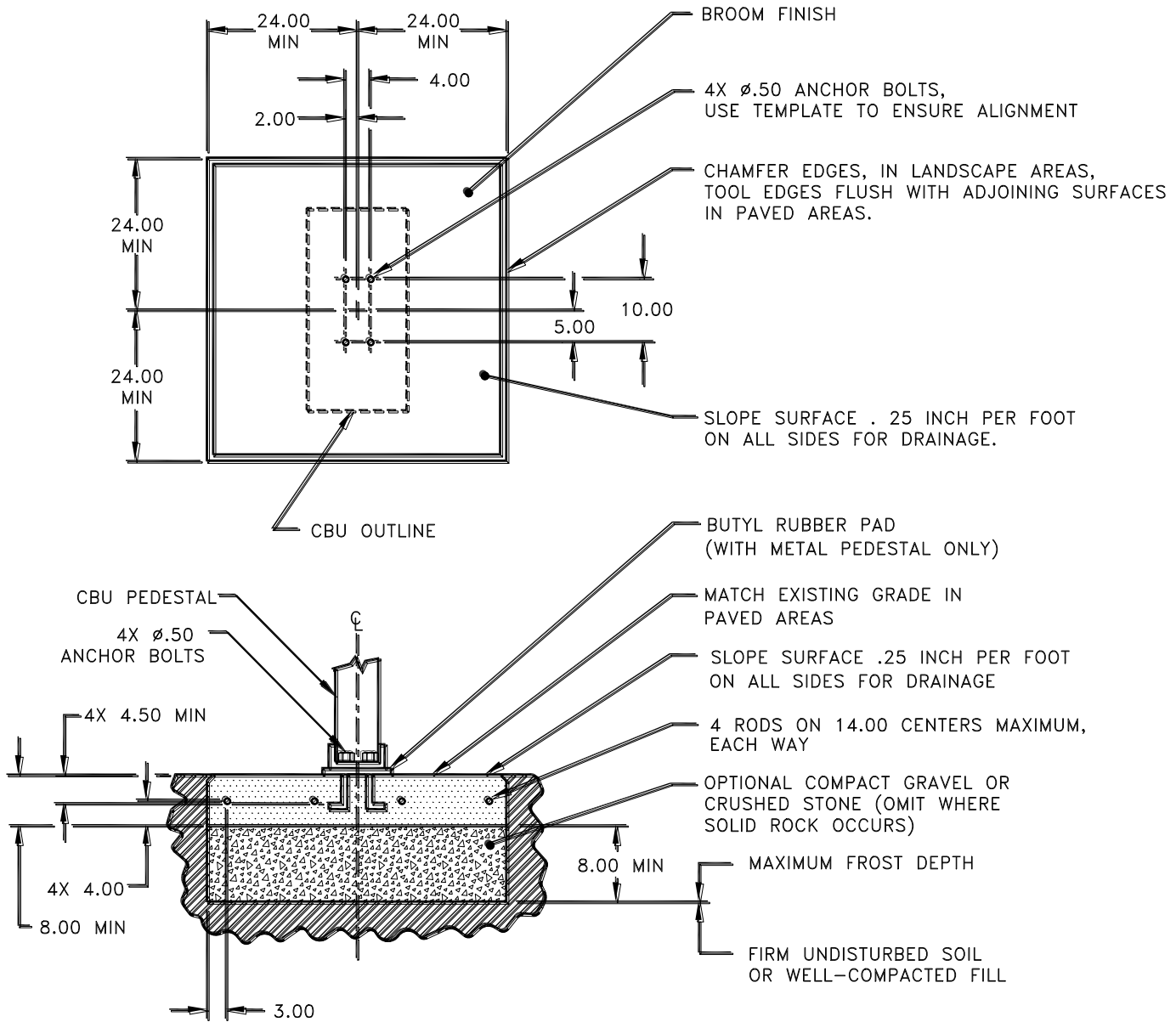

NOTES:

1. CONCRETE SHALL HAVE A COMPRESSIVE STRENGTH OF 3000 PSI @ 28 DAYS, CONTAIN 4% MIN – 6% MAX AIR ENTRAINMENT AND BE PLACED WITH A 3.50 – 4.50 SLUMP IN ACCORDANCE WITH ACI 301.
2. REINFORCING STEEL RODS SHALL CONFORM TO ASTM A615, GRADE 60.
3. ANCHOR BOLTS SHALL CONFORM TO ASTM A193, GRADE B8M, TYPE 316 STAINLESS STEEL.

USPS APPROVED SPECIFICATIONS – CONCRETE PAD (MULTIPLE UNIT)

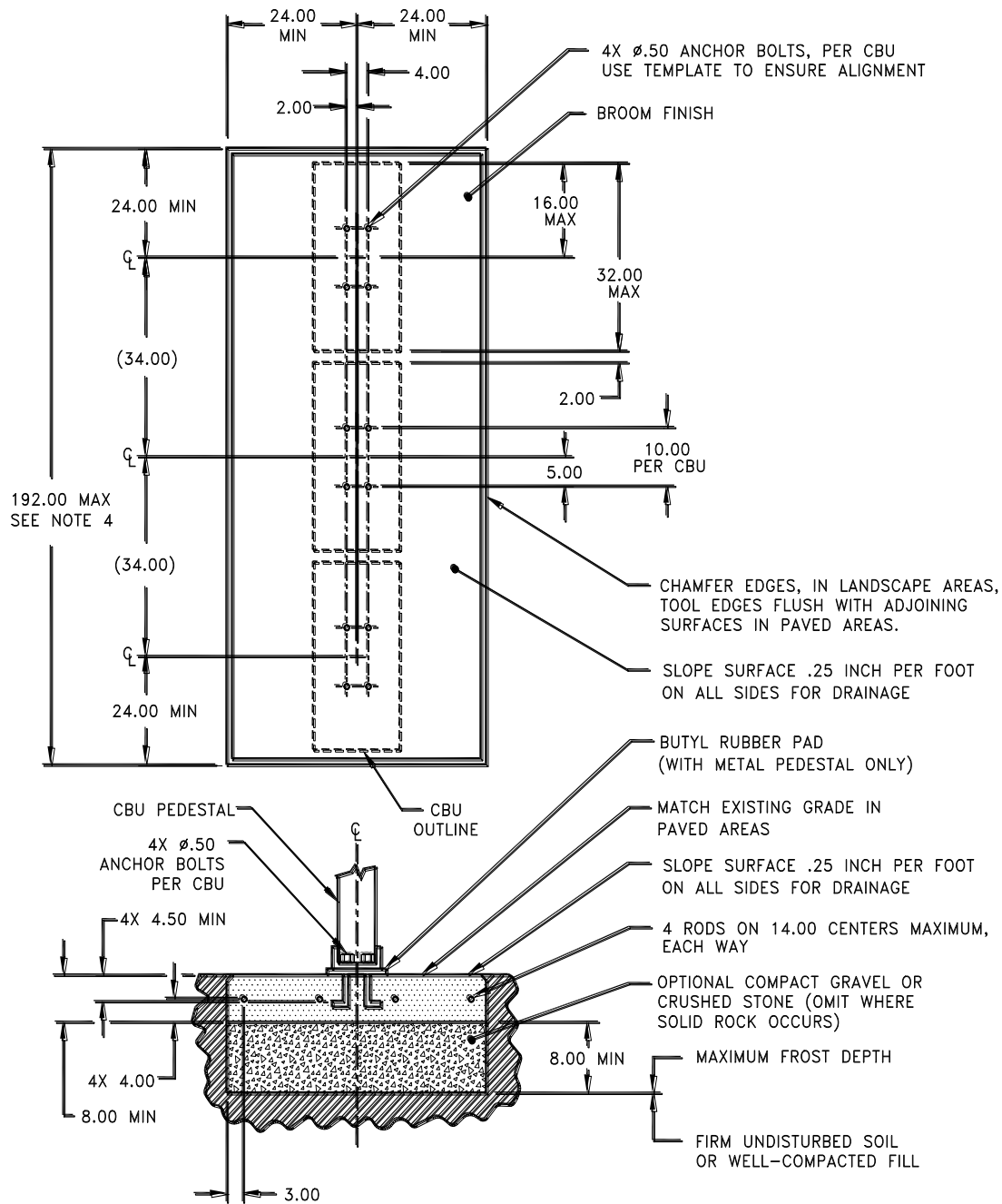

NOTES:

1. CONCRETE SHALL HAVE A COMPRESSIVE STRENGTH OF 3000 PSI @ 28 DAYS, CONTAIN 4% MIN - 6% MAX AIR ENTRAINMENT AND BE PLACED WITH A 3.50 - 4.50 SLUMP IN ACCORDANCE WITH ACI 301.
2. REINFORCING STEEL RODS SHALL CONFORM TO ASTM A615, GRADE 60.
3. ANCHOR BOLTS SHALL CONFORM TO ASTM A193, GRADE B8M, TYPE 316 STAINLESS STEEL.
4. A 3 CBU CONFIGURATION IS DEPICTED. A 2 OR 4 CBU CONFIGURATION MAY BE USED AS LONG AS THEY ARE ARRANGED IN GROUPS SUCH THAT THE OVERALL DIMENSION OF THE CONCRETE BASE DOES NOT EXCEED 192 INCHES.

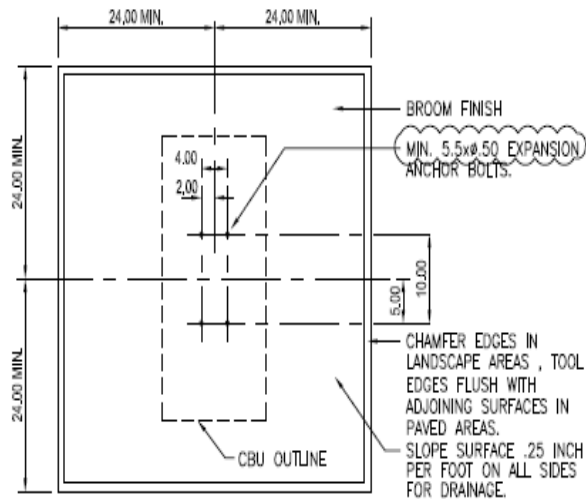

PLAN

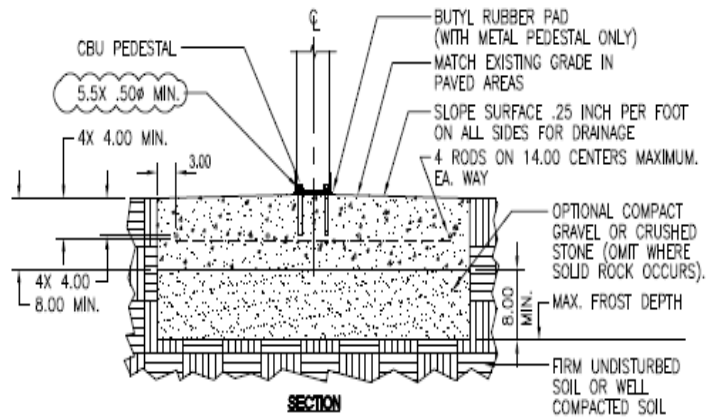

SECTION

NOTES:

1. CONCRETE SHALL HAVE A COMPRESSIVE STRENGTH OF 3,000 PSI @ 28 DAYS, CONTAIN 4% MIN. - 6% MAX. AIR ENTRAINMENT AND BE PLACED WITH A 3.50-4.50 SLUMP IN ACCORDANCE WITH ACI 301
2. REINFORCING STEEL RODS SHALL CONFORM TO ASTM A615, GRADE 60.
3. EXPANSION BOLTS SHALL BE EQUIVALENT TO THE FOLLOWING PROVIDERS:
 - a. HILTI KWIK BOLT (www.us.hilti.com) 1/2" DIAMETER x 5-1/2" OVERALL LENGTH GALVANIZED, CATALOG #: 000-453-696 KB II 12-512, STAINLESS STEEL; CATALOG #: 000-454-744 ENSURE THAT THE MIN. EMBEDMENT IN CONCRETE IS AT LEAST 3-1/2".

- b. ITW RAMSET REDHEAD TRUBOLT (www.ramset-redhead.com) GALVANIZED, 1/2" DIAMETER x 7" OVERALL LENGTH; CATALOG NUMBER: WS-1270G ENSURE THAT THE MIN. EMBEDMENT IN CONCRETE IS AT LEAST 4-1/8".
- c. RAWL STUD (www.rawl.com) GALVANIZED, 1/2" DIAMETER x 5-1/2" OVERALL LENGTH; CATALOG NUMBER: 7724 ENSURE THAT THE MIN. EMBEDMENT IN CONCRETE IS AT LEAST 4".

Detail:

CLUSTER BOX UNIT (CBU) INSTALLATION - SINGLE UNIT

Fac. Ch. Sect. Para. Detail

G1-2-0e

CAD File:

../usps/library/details/G1-2-0e

Scale:

1/2" = 1'-0"

USPS SDL Issued: 10/1/2016
Last Revised: 10/27/2016



STANDARD DETAIL LIBRARY

NOTES TO A/E:

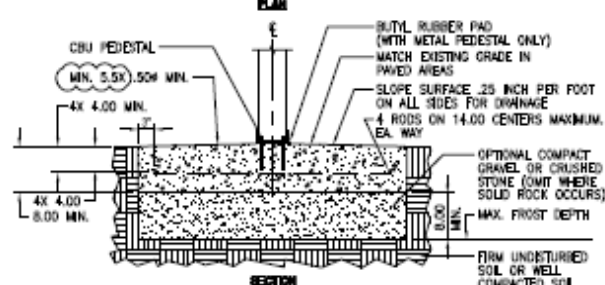
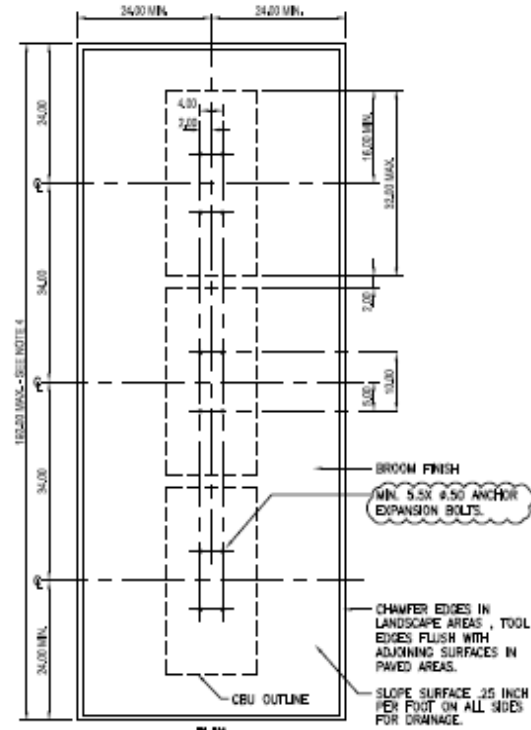

- NOTES:**
1. CONCRETE SHALL HAVE A COMPRESSIVE STRENGTH OF 3,000 PSI @ 28 DAYS, CONTAIN 4% MIN. - 6% MAX. AIR ENTRAINMENT AND BE PLACED WITH A 3.50 - 4.50 SLUMP IN ACCORDANCE WITH ACI 301
 2. REINFORCING STEEL RODS SHALL CONFORM TO ASTM A615, GRADE 60
 3. EXPANSION BOLTS SHALL BE EQUIVALENT TO THE FOLLOWING PROVIDERS:
 - a. HDI KMK BOLT (www.hdi.com) 1/2" DIAMETER x 5-1/2" OVERALL LENGTH
GALVANIZED, CATALOG # 000-453-898
NF # 12-512, STAINLESS STEEL: CATALOG # 000-454-744
ENSURE THAT THE MIN. EMBEDMENT IN CONCRETE IS AT LEAST 3-1/2".
 - b. ITW RAMSET RE-HEAD TRUBOLT (www.ramset-redhead.com)
GALVANIZED, 1/2" DIAMETER x 7" OVERALL LENGTH; CATALOG NUMBER: WS-12700
ENSURE THAT THE MIN. EMBEDMENT IN CONCRETE IS AT LEAST 4-1/8".
 - c. RAWL STUD (www.rawl.com)
GALVANIZED, 1/2" DIAMETER x 5-1/2" OVERALL LENGTH; CATALOG NUMBER: 7724
ENSURE THAT THE MIN. EMBEDMENT IN CONCRETE IS AT LEAST 4".
 4. A 3 CBU CONFIGURATION IS DEPICTED. A 2 OR 4 CBU CONFIGURATION MAY BE USED AS LONG AS THEY ARE ARRANGED IN GROUPS SUCH THAT THE OVERALL DIMENSION OF THE CONCRETE BASE DOES NOT EXCEED 16 FEET.

Detail:	CLUSTER BOX UNIT (CBU) INSTALLATION - MULTIPLE UNIT	Fac.	Ch.	Sept.	Para.	Detail
						G1 - 2 - 0 e1
CAD File:	./uaps/library/details/G1-2-0e1	Scale:	1/2" = 1'-0"			USPS SDI Issued: 10/1/2016 Last Revised: 10/27/2016



STANDARD DETAIL LIBRARY

1. IF THE ACCESSIBLE ROUTE FROM THE CBU(S) CONNECTS WITH A STREET OR OTHER PAVED SURFACE AT A VERTICAL CURB, A CURB RAMP SHOULD BE INSTALLED IN ACCORDANCE WITH RE-4 REQUIREMENTS.

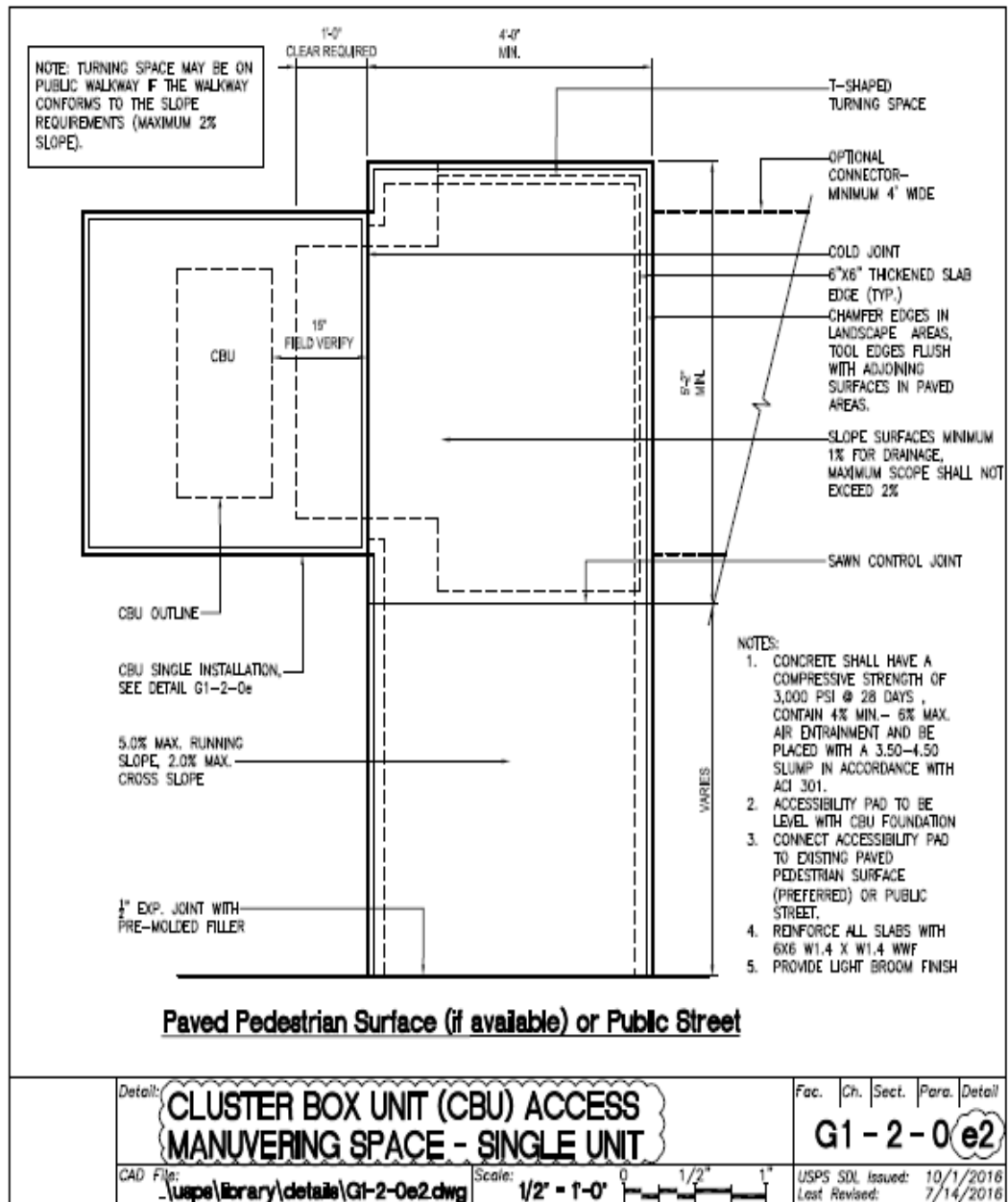

STANDARD DETAIL LIBRARY

NOTES TO A/E:

IF THE ACCESSIBLE ROUTE FROM THE CBU(S) CONNECTS WITH A STREET OR OTHER PAVED SURFACE AT A VERTICAL CURB, A CURB RAMP SHOULD BE INSTALLED IN ACCORDANCE WITH RE-4 REQUIREMENTS.

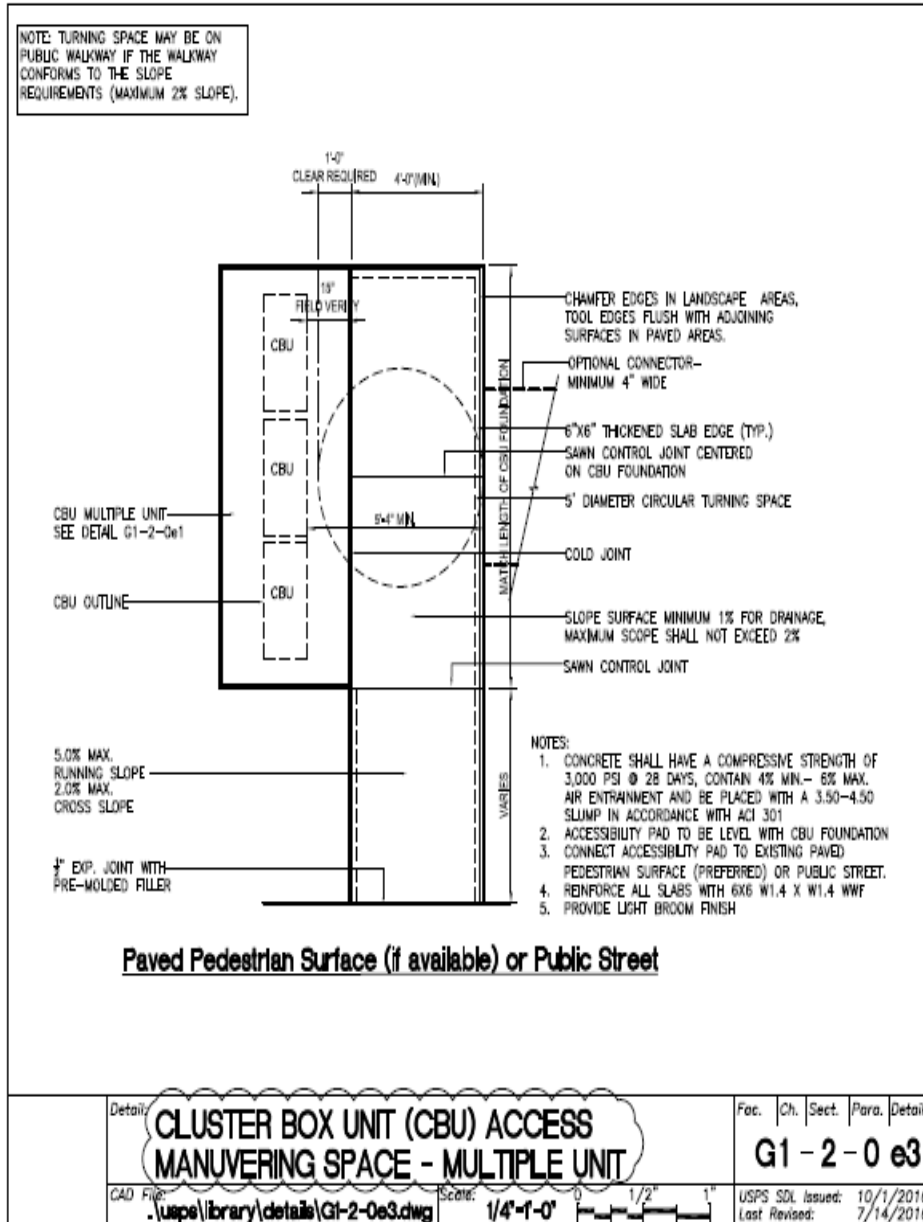

STANDARD DETAIL LIBRARY

**CLUSTER BOX UNIT (CBU)
-ANCHORING METHODS-**

CBU's must be level and mounted firmly in concrete, using one of the following methods.

1. The J-bolt method is the preferred method of installation of CBU's on concrete pads; however, the J-bolt pattern must be accurate with the CBU pedestal plate. When using J-bolts, in order to prevent any damage or accidents that could result from the exposed bolts, consideration should be given as to the time lapse between pouring the concrete and the actual installation. Expansion anchors must be installed in accordance with the manufacturer's instructions.
2. The use of anchor bolts for the installation of CBU's on concrete pads is also acceptable as long as the methods described below are followed.
 - a. Hilti Kwik bolt II, 1/2" diameter X 5-1/2" overall length
Catalog Number: 000-453-696, KB II 12-512
Stainless Steel Catalog Number: 000-454-744
Minimum embedment in concrete must be no less than 3-1/2"
 - b. ITW Ramset Redhead Trublott, galvanized, 1/2" diameter X 7" overall length
 - c. Rawl Stud, 1/2" diameter X 5 1/2" overall length, galvanized.
Catalog Number: 7324
Minimum embedment in concrete must be no less than 4"

**CLUSTER BOX UNIT (CBU)
-CONCRETE PAD REQUIREMENTS-**

- ALL FREE STANDING PADS MUST BE 8" THICK -

1 UNIT	SINGLE PAD	4' X 4'
2 UNITS	DOUBLE PAD	4' X 7'
3 UNITS	TRIPLE PAD	4' X 10'
4 UNITS	QUAD PAD	4' X 13'

***** WHEN PLACING A PARCEL LOCKER AT ANY CBU LOCATION, INCREASE THE
PAD SIZE BY AN ADDITIONAL 4' X 4'*****

This CBU is properly installed—the future sidewalk has been taken into consideration.



The picture above shows a similar install in a finished neighborhood.



These CBU's are properly installed to be level on this steep hill.

**REFER TO THE FOLLOWING PHOTOGRAPHS
FOR ILLUSTRATIONS OF BOTH
C😊RECTLY AND INC😊RECTLY
INSTALLED CBU'S**



INCORRECT - THIS REPRESENTS A SAFETY HAZARD, IS VULNERABLE TO TRAFFIC, AND VIOLATES ADA REQUIREMENTS. THERE SHOULD BE 36 INCHES IN FRONT OF THE CBU FOR WHEELCHAIR ACCESS.



INCORRECT - THE PAD IS TOO SMALL.



CORRECT - IF THIS CBU WAS INSTALLED NEXT TO THE CURB IT WOULD OFTEN BE BLOCKED BY PARKED CARS AND THE CARRIER WOULD NOT BE ABLE TO OPEN IT.



CORRECT - TO REDUCE MAINTENANCE COSTS, INSTALL CBU AWAY FROM THE STREET. CBU'S ARE EASILY DAMAGED WHEN INSTALLED NEXT TO THE STREET.



INCORRECT - THE ADA REQUIRES THAT SIDEWALKS REMAIN CLEAR.



CORRECT – NOTE HOW MUCH CONCRETE WAS REQUIRED IN ORDER TO MEET LOCAL CODES.



CORRECT – PLAN AHEAD. THIS PAD WAS ACTUALLY POURED BEFORE THE SIDEWALK WAS PUT IN. THE DIMENSIONS, ELEVATION, AND SLOPE WERE CALCULATED TO MATCH THE FUTURE SIDEWALK.



CORRECT - WHEELCHAIR ACCESSIBLE. SET BACK FROM THE ROADWAY. EASY ACCESS FOR THE CARRIER.



CORRECT



CORRECT - THE RETAINING WALL SHOWS HOW IMPORTANT IT IS TO INSTALL THE CBU AWAY FROM THE STREET.



CORRECT - PLACING THE CBU BEHIND THE SIDEWALK INSTEAD OF NEXT TO THE STREET HELPS TO PROTECT THEM FROM VEHICLES WHILE NOT IMPEDING PEDESTRIANS OR WHEELCHAIRS.



INCORRECT - THE PEDESTAL IS EMBEDDED IN THE CONCRETE MAKING THE CBU VERY DIFFICULT TO MAINTAIN.



INCORRECT – LOCATED IN FRONT OF A PUBLIC OFFICE BUILDING - THE CBU SHOULD BE ACCESSIBLE FROM THE SIDEWALK.



INCORRECT - LEANS OVER THE CURB. BLOCKS THE SIDEWALK.



INCORRECT - THE CONCRETE PAD ANCHORING THIS CBU IS TOO SMALL. ALSO, THE CBU IS FACING THE STREET. CUSTOMERS SHOULD NOT HAVE TO STEP OFF THE CURB INTO THE STREET TO GET THEIR MAIL.



**MODE OF DELIVERY AGREEMENT
TENNESSEE DISTRICT**

NAME OF PROJECT _____
ADDRESS OF PROJECT _____ **DATE** _____
POST OFFICE/ZIP CODE _____ **PROPOSED ROUTE #** _____
This Project is: **NEW CONSTRUCTION** ___ **RENOVATION** ___ (If renovation, please complete conversion request)
Estimated 1ST Occupancy Date: _____ **10% Occupancy:** _____ **Completion:** _____
Delivery options will be explained by USPS representative (options shown in gray below).

<u>Type of Project</u>	<u>Deliveries</u>	<u>Equipment-Type / #</u>	<u>EQUIPMENT OPTIONS</u>
Office Bldg (___ Floors)	_____	_____	CBU Type I (8 Del)
Shopping Mall	_____	_____	CBU Type II (12 Del)
Strip Mall	_____	_____	CBU Type III (16 Del)
Apts./Condos (___ Floors)	_____	_____	CBU Type IV (13 Del)
Townhouses	_____	_____	Curb line 2/post
Single Family Homes	_____	_____	Curb line 4/post
Trailer Park	_____	_____	Wall mount STD 4C
Other (Specify)	_____	_____	

DEVELOPER / CONTRACTOR / OWNER RESPONSIBILITY IS AS FOLLOWS:

Location and installation of all receptacles must be approved by USPS representative.

Concrete pads for CBU's are required to meet USPS specifications.
Concrete pads for CBU's are installed by: Developer X other ___
Equipment purchased by: Developer X other ___
Equipment installed by: Developer X other ___
Equipment owned/maintained by: Developer X other ___
Keys issued to residents by: Developer X USPS ___ other ___
Locks changed by: Developer ___ USPS ___ other ___

Residents of single-family homes must be informed of their ongoing responsibility for keys; box maintenance/repair, snow removal, etc.

Note: On multi-tenant delivery and/or rental situations, the building owner/manager is responsible for lock changes. Owner/manager will handle parcels and accountable? Yes ___ No ___

This notice will serve as an Agreement / Letter of Consent to the Postal Service for the placement of Centralized Delivery Equipment at the agreed upon location(s) indicated on the plat map. By signing below, I acknowledge that the contractor options and responsibilities outlined above for receiving mail delivery service have been discussed with me.

USPS REPRESENTATIVE	PROPERTY DEVELOPER/MGR/OWNER
NAME _____	NAME _____
TITLE _____	TITLE _____
SIGNATURE _____	SIGNATURE _____
TELEPHONE # _____	TELEPHONE # _____
DATE _____	DATE _____

This agreement is subject to final approval by District Operations Programs Support. Submit completed agreement and other required attachments to:

Growth Management, Operations Programs
525 Royal Pkwy
Nashville, TN 37229-9321

**USPS APPROVED MANUFACTURERS OF
CLUSTER BOX UNITS (CBUs) & WALL-MOUNTED CENTRALIZED MAIL RECEPTACLES
(USPS-B-1118F, USPS-STD-4B+ AND USPS-STD-4C)**

USPS-STD-B-118F

COMPANY	ADDRESS	CITY	STATE	ZIP	PHONE	WEB SITE	DESIGN TYPES
Auth-Florence Manufacturing	5935 Corporate Dr.	Manhattan	KS	66503-9675	800-275-5081	www.auth-florence.com	Types 1,11,111 & IV

USPS -STD-4B+

COMPANY	ADDRESS	CITY	STATE	ZIP	PHONE	WEB SITE	DESIGN TYPES
American Device Manufacturing	5935 Corporate Dr.	Manhattan	KS	66503-9675	800-275-5081	www.auth-florence.com	Horizontal units only
American Eagle	3017 Wheel Lock St	Dallas	TX	75220-2944	214-358-5544	www.americaneaglemailbox.com	Horizontal units only
Auth-Florence Manufacturing	5935 Corporate Dr.	Manhattan	KS	66503-9675	800-275-5081	www.auth-florence.com	Horizontal & Vertical Units
Bommer Industries	PO Box 187	Landrum	SC	29366-0187	800-334-1654	www.bommer.com	Horizontal & Vertical Units
Jensen Industries	1946 E 46th St	Los Angeles	CA	90058-2096	800-235-8351	www.jensen-ind.com	Horizontal & Vertical Units
Salisbury Industries	1010 East 62nd St	Los Angeles	CA	90001-1598	800-323-3003	www.mailboxes.com	Horizontal & Vertical Units
Security Manufacturing	815 S Main St	Grapevine	TX	76051-5535	800-762-6937	www.securitymanufacturing.com	Horizontal & Vertical Units

USPS -STD-4C

COMPANY	ADDRESS	CITY	STATE	ZIP	PHONE	WEB SITE	DESIGN TYPES
Postal Products Unlimited	500 W Oklahoma Ave	Milwaukee	WI	53207-2649	800-229-4500	www.mailproducts.com	Horizontal

Notes: Buildings with permits dated on or after October 5th, 2006 must have USPS-STD-4C receptacles.

Encourage Customers to sign up for Informed Delivery/Predictive

<https://informedelivery.usps.com/box/pages/intro/start.action>

The Customer will be able to see the mail/packages arriving in their mailbox

1. Create Your Account
Use your personal *USPS.com*[®] account or sign up for one today.

2. Verify Your Identity
Protect your privacy and personal information by verifying your identity and address.

3. Receive Notifications
View notifications from any smartphone, tablet, or computer.

[Sign Up for Free](#)

Secure Access
Interact with your incoming mail and packages on the secure, online dashboard.

Preview Incoming Mail
View grayscale images of the exterior, address side of letter-sized mailpieces scheduled to arrive soon.*

Track Packages
Check the delivery status of packages and when they're scheduled to arrive.

Delivery Instructions
Leave delivery instructions if you won't be home to accept a package.

Schedule Redelivery
Missed a delivery? Schedule a package to be redelivered.

Manage Notifications
Set up email and/or text notifications to track the delivery status of your package(s).





U. S. Postal Service National Delivery Planning Standards A Guide for Builders and Developers



PRIORITY:YOU

Table of Contents

1	Introduction	3
2	Finding Your Growth Manager and USPS Online Resources	4
2.1	Find a Post Office	4
2.2	Find Your Local USPS Growth Manager	4
2.3	USPS-Approved Mailbox Equipment.....	4
2.4	Delivery Planning Resources for Builders and Developers.....	5
3	General Planning Guidelines for Mailboxes in New Developments.....	5
3.1	Letter Carrier Access to Deliver U.S. Mail	5
3.2	Mailbox Locks and Keys	5
3.3	USPS Master Access Lock	6
3.4	Safety Considerations	6
3.5	Customer and Carrier Accessibility Considerations.....	6
3.5.1	Placement of Outdoor Cluster Boxes	6
3.5.2	Construction Accessibility Guidelines	6
4	Single-point Residential Deliveries	7
4.1	Residential Single Family Site Constructed Development.....	7
4.2	Residential Mobile or Trailer Home Development	7
5	Multi-point Residential Deliveries.....	8
5.1	Apartment Communities.....	8
5.2	Student Housing and Off-Campus Student Apartment Communities.....	8
6	Non-Residential Deliveries	9
6.1	Business and Industrial Parks	9
7	General Delivery Planning Information	9
8	Inspection and Commencement of Mail Delivery Services	10
8.1	Mail Receptacles and Customer Obligations.....	10
8.2	Centralized Mail Receptacle Installation.....	10
9	Closing.....	11
	APPENDIX A – Cluster Box Unit Installation Single Unit.....	12
	APPENDIX B – Cluster Box Unit Installation Multiple Unit	13
	APPENDIX C – Cluster Box Unit Access Maneuvering Space – Single Unit.....	14
	APPENDIX D – Cluster Box Unit Access Maneuvering Space – Single Unit.....	15

1 Introduction

The United States Postal Service® is proud to provide every new home and business with excellent, efficient mail delivery service. This guide will assist you in preparing your new development for mail service by planning locations and space for mail equipment early in the development process.

The U.S. Postal Service™ is responsible for establishing the method or “mode” of delivery for all new developments—both residential and commercial. The mode of delivery includes the following:

- Type of mailbox you will use.
- Location of the mailbox for each delivery address.

Centralized delivery is our preferred method of mail delivery. Centralized delivery equipment improves delivery efficiency and provides space for large mail items, including packages, which is a great benefit for customer. Freestanding, pedestal-style outdoor centralized mailboxes are called cluster box units or CBUs. CBUs are “package friendly” because they are designed to accommodate the majority of packages delivered through the U.S. Mail®. CBUs also include parcel lockers, which provide separate, locked storage for many packages.

Other types of centralized mailbox equipment are also available. Builders and developers or property owners are responsible for the purchase, installation, maintenance, repair, and replacement of mailbox equipment.

This guide provides information about the types of USPS-approved mailbox equipment options available commercially and information about other aspects of mail delivery planning that may apply to your specific development.

With more than 150 million households and businesses served daily—and another 1 million new delivery points added on average every year—it is imperative that the U.S. Postal Service make its mail delivery network more efficient while still delivering the service our customers expect. We appreciate your assistance in furthering that objective, while at the same time helping provide new customers with convenient mail delivery for their new homes and businesses.

We also want to connect you with local USPS® delivery planning individuals in your area—referred to as Growth Managers. Postal Service Growth Managers are available to assist you. Prior to submitting your master plan and plat to the local municipality and/or county for approval, you must arrange for a local USPS Growth Manager to review your development plans prior to commencing construction.

Thank you for reviewing the Postal Service’s mail delivery-planning standards—we look forward to working with you!

2 Finding Your Growth Manager and USPS Online Resources

2.1 Find a Post Office

The Postal Service lists all local Post Offices™ on its website at: www.usps.com. To find the Post Office closest to your new development, search using the appropriate ZIP Code™.

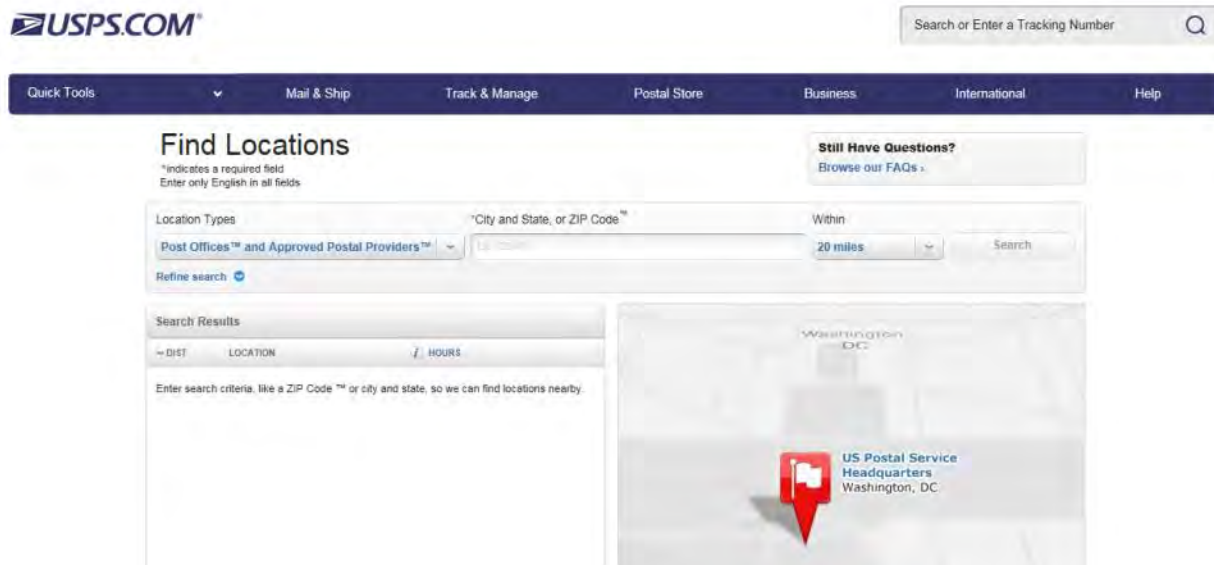

2.2 Find Your Local USPS Growth Manager

Every area where the U.S. Postal Service provides mail delivery has a Postal Service employee assigned to help developers and builders with planning mail service for new development. These “new delivery planning” employees are referred to as Growth Managers.

To find the Growth Manager that covers your specific development’s geographic location, send an email to: Delivery.Growth@USPS.GOV, or contact your Post Office and ask to speak to either the Postmaster or the person assigned to assist developers with planning new mail service.

2.3 USPS-Approved Mailbox Equipment

Mailboxes used in new construction projects can be one of the following two types of centralized mailbox equipment:

1. Pedestal-mounted USPS-approved CBU.
2. Wall-mounted USPS-approved STD-4C mailboxes (4C).



The Postal Service annually publishes a list of USPS-approved mailbox equipment and approved manufacturers in its *Postal Bulletin*.

<http://about.usps.com/postal-bulletin/2017/pb22467/html/welcome.htm>

You can also find the latest list of USPS-approved equipment and approved manufacturers at:
<http://about.usps.com/what-we-are-doing/current-initiatives/delivery-growth-management/welcome.htm>

2.4 Delivery Planning Resources for Builders and Developers

The most current version of this guide will always be available on the webpage at:
<http://about.usps.com/what-we-are-doing/current-initiatives/delivery-growth-management/welcome.htm>

The following links provide additional resources for builders and developers:

- Find a Post Office: <https://tools.usps.com/go/POLocatorAction!input.action>.
- Centralized Delivery/Residential Applications: <http://about.usps.com/publications/pub265a.pdf>.
- Centralized Delivery/Garden Apt Applications: <http://about.usps.com/publications/pub265c.pdf>.
- Centralized Delivery/Commercial Applications: <http://about.usps.com/publications/pub265b.pdf>.

3 General Planning Guidelines for Mailboxes in New Developments

3.1 Letter Carrier Access to Deliver U.S. Mail

Centralized delivery is the Postal Service's preference for new addresses, whether residential or commercial. The customer is responsible for keeping the approach to his or her mailbox and adjacent area clear to facilitate delivery. You may provide curbside delivery only with prior approval from the Postal Service. Place curbside mail receptacles approved by the Postal Service where they protect the mail, can be safely and conveniently serviced by carriers without leaving their vehicles, and can be reasonably and safely accessed by customers. These receptacles must be on the right-hand side of the road in the direction of travel when required by traffic conditions, or when driving on the left-hand side of the road to reach the mail receptacle would violate traffic laws.

3.2 Mailbox Locks and Keys

The Postal Service prohibits carriers from accepting keys for locks on private mail receptacles, buildings, or offices, except where an electromechanical door lock system or key keeper box is used.

CBUs have secure, locking mailbox and parcel locker compartments. Whether your new development is commercial or residential, the builder or property owner is responsible for providing lock and key service for cluster box units. The locks/keys for each of the compartments will be provided with the CBU. The Postal Service will furnish the "master access lock" that allows mail to be delivered. See 3.3 for more information.

Your local USPS Growth Manager will discuss specific requirements and processes appropriate for your new development as part of the overall coordination process related to establishing the mode of delivery for your new development.

3.3 USPS Master Access Lock

The Postal Service will furnish its own “master access lock” so that carriers have access to deliver the mail. This lock is not available to developers and builders to pre-install.

Your local USPS Growth Manager will coordinate installation of the “master lock” as part of the overall coordination process when starting new mail delivery for customers.

3.4 Safety Considerations

If curb delivery is approved by the Postal Service, posts and other supports for curbside mailboxes are owned and controlled by the customer. The owner of the property is responsible for ensuring that posts are neat and adequate in strength and size.

When installing centralized delivery equipment, such as CBUs or STD-4C (4C) equipment, the mailboxes must be safely located so that customers are not required to travel an unreasonable distance to obtain their mail. Typically, mailbox receptacles are located within 1 block of the residence.

When new developments, either residential or commercial, are in the design phase, developers or architects must meet with the USPS Growth Manager to ensure that safe and durable receptacles are properly specified and located in conformance with regulations. The Growth Manager will also meet with the builder at the appropriate time during the construction phase to review the physical mailroom installation and discuss coordination and timing of initiating mail delivery.

3.5 Customer and Carrier Accessibility Considerations

Curb delivery may only be provided with prior approval from the Postal Service if the carrier can efficiently, safely, and conveniently service the mailbox from the carrier’s vehicle and if the customer can safely and easily access the mailbox.

Apartment house delivery requires that mailboxes be located reasonably close to the entrance in vestibules, halls, or lobbies. The carrier must also be able to service the boxes without interference from swinging or open doors. Consult with your local USPS Growth Manager early in the design process to ensure you select an appropriate location for the apartment building mailroom.

3.5.1 Placement of Outdoor Cluster Boxes

The local USPS Growth Manager or designee must approve the CBU mailbox sites and type of equipment. Cluster boxes must be safely located so that customers are not required to travel an unreasonable distance to obtain their mail and so there is sufficient access to mailbox locations with adequate space for carriers to deliver and customers to retrieve the mail. Typically, a mailbox receptacle will be located within 1 block of the residence.

3.5.2 Construction Accessibility Guidelines

Accessibility requirements and regulations, including those required to accommodate customers with disabilities, may vary by type of facility and governing jurisdiction. Always consult local building officials and codes for applicable accessibility requirements that apply to your specific development and mailbox project.

4 Single-point Residential Deliveries

New mail delivery planning for single-family residential developments typically falls into the following two primary categories:

- Site-constructed single family homes.
- Mobile or trailer homes.

4.1 Residential Single Family Site Constructed Development

During the design and planning phase (i.e., before plans and site plats are finalized with the appropriate planning/zoning authorities), developers and builders must notify the U.S. Postal Service of the planned development so that the Postal Service can determine the appropriate mode of delivery while considering input from the parties involved with the development.

Developers and builders must plan to install centralized mail delivery receptacles in new residential communities, which include secure parcel lockers.

New homes built or established within a block of existing homes can only receive the same type of mail delivery service as the older, existing homes after the Postal Service has completed an operational efficiency analysis. When new delivery replaces more than 1 block, delivery methods must comply with mode of delivery options for establishment and extension of delivery service, which is typically centralized mail service.

Your local USPS Growth Manager will work closely with you to determine the best approach to providing mail delivery service to customers in your new residential development. It is important that you contact the Growth Manager in your area as early as possible in your planning process.

4.2 Residential Mobile or Trailer Home Development

The delivery options for mobile or trailer home developments depend on whether the development is *permanent* or *transient* as determined by the Postal Service.

Permanent Developments—Permanent developments consist of managed mobile home parks or residential mobile home subdivisions with the following characteristics:

- The lots are permanently assigned.
- The streets are maintained for public use.
- The conditions resemble those of a residential subdivision.

For permanent developments, the delivery options are either central, curbside, or sidewalk delivery. The Postal Service will determine and specify the type of mail delivery for any permanent mobile/trailer home development. The general practice of the Postal Service is to specify centralized delivery.

Transient Developments—Transient developments are mobile home, trailer, and recreational vehicle parks where the lots are temporarily occupied or rented and considered transient, short-term, or seasonal. For transient developments, the only option is delivery to a single point or receptacle designated by park management and approved by local Postal Service management. The single delivery point defined will be for the receipt of all mail from USPS; employees of the park will complete the subsequent distribution of mail and forwarding.

Whether your new mobile home development is permanent or transient, contact your local Growth Manager early in the process so that we can work with you in laying out the space plan for mail delivery for the residents of your new community.

5 Multi-point Residential Deliveries

5.1 Apartment Communities

The following are important U.S. Postal Service guidelines for determining the location and composition of mail receptacles for apartment communities:

- a. All new or remodeled apartment houses must install USPS-approved 4C centralized mailbox equipment. There must be at least 1 parcel locker for every 10 mailbox compartments. The Postal Service requires no maximum number of parcel lockers to be installed—only the 1:10 parcel locker/mailbox minimum.
- b. Lock mail receptacles and parcel lockers in apartment buildings reasonably close to the entrance in vestibules, hall, or lobbies. The carrier must also be able to serve the boxes without interference from swinging or open doors.
- c. Exterior centralized mailboxes may also be an option. The Postal Service may authorize the installation of standard, approved apartment receptacles (4C or CBU) in exterior walls of buildings provided they are not installed directly on the street or a public sidewalk. Provide a canopy for outdoor mailbox installations. The canopy design and location must provide maximum protection from the weather, including driving rain, and provide adequate nighttime lighting.

5.2 Student Housing and Off-Campus Student Apartment Communities

Mail delivery protocols to student housing vary depending on the characteristics of the student housing community being served. Below are general guidelines for establishing new mail service.

Mail is delivered to dormitory buildings and residence halls when addressed to a specific building. Mail is delivered in bulk to a designated representative of the school or property in the building. The representative is responsible for further distribution to students/residents. The Postal Service will determine the proper mode of delivery to be established and may require that designees from the student housing property be identified to accept mail for each location prior to initiating delivery.

The Postal Service defines a dormitory building or residence hall as a building that consists of single or multi-room units that may share or have access to centrally located kitchens, bathrooms, showers, or social or common areas. Whether located on or off campus, and regardless of private ownership, such buildings are nevertheless dormitories and either the school or building owner is responsible for the final delivery of student mail. Post Office personnel do not distribute mail into apartment-type mailboxes for dormitories or residence halls.

As always, it is important to contact your local USPS Growth Manager early in the planning process to ensure understanding and requirements related to providing mail delivery for your new student housing development.

6 Non-Residential Deliveries

6.1 Business and Industrial Parks

The following paragraphs provide important U.S. Postal Service guidelines for determining the location, type of mailbox receptacles and other requirements related to initiating new mail delivery for business and industrial parks:

The type and design of buildings included in the business and industrial park will govern the mode of delivery that is implemented. As with all new mail delivery planning, the location of the USPS-approved delivery equipment is subject to Postal Service approval. Delivery mode options for business parks are door, centralized, curbside, or sidewalk delivery. Door delivery will generally not be available for new delivery points. The primary options are as follows:

- a. **Centralized Delivery.** Centralized delivery service applies to all business office buildings, office complexes, and industrial and professional parks. If the U.S. Postal Service is delivering directly to the mailboxes, the type of equipment allowed for newly constructed buildings must either be USPS-approved CBUs or STD-4C (4C) wall-mounted receptacles.
- b. **Single-Point Delivery.** Single-point delivery is generally not available to new business park developments unless it is in the form of a bulk mail drop.

7 General Delivery Planning Information

7.1 Establishment of City Delivery Service

To establish city delivery service, consider a combination of mail delivery methods to provide regular and effective service to all residential and business sections of a community. Consider the establishment of city delivery service when the following requirements are met:

- a. Within the area to be served, there is a population of 2,500 or more or 750 possible deliveries.
- b. At least 10 percent of the building lots in the area to be served are improved with houses or places of business. Where a house or building and its yard or ground cover more than one lot, all lots so covered are considered improved. The streets are paved or otherwise improved to permit the travel of Postal Service vehicles at all times, without damage or delay.
- c. Streets are named and house numbers are assigned by the municipal authorities in accordance with Management Instruction DM-940-89-3, *Addressing Conventions*.
- d. Street signs are in place and house numbers are displayed.
- e. Rights-of-way, turnouts, and areas next to the roads and streets are sufficiently improved so that the installation, servicing, and accessing of mailboxes are not hazardous to the public or Postal Service employees.
- f. Satisfactory walkways exist for the carrier where required.

Note: During a new residential or commercial development's design and planning phase (i.e., before the developers and builders finalize plans and site plats with the appropriate planning/zoning authorities), developers and builders must notify the Postal Service so that the Postal Service can determine the appropriate mode of delivery while considering input from these parties.

Developers and builders should plan for centralized mail delivery installations for residential communities or business developments.

It is important to contact your local USPS Growth Manager while you are still in the design process so that we can collaborate with you to prepare the most efficient, effective plan to provide mail delivery for the customers who will live or work in your new development.

8 Inspection and Commencement of Mail Delivery Services

8.1 Mail Receptacles and Customer Obligations

Appropriate mail receptacles must be provided for the receipt of mail. The type of mail receptacle depends on the mode of delivery in place. Purchase, installation, maintenance, repair, and replacement of mail receptacles are the responsibility of the customer. Verify with the local Postmaster or Growth Manager, the appropriate locations for installation. The following apply:

- a. In locations where the Postal Service has determined that centralized delivery is appropriate, customers must install mail receptacles that comply with the USPS STD- 4C wall-mounted mail receptacles or USPSB1118, Postal Service specification, CBUs, to include secured parcel lockers.
- b. If curblin delivery is authorized, customers must erect curb-mounted receptacles that comply with USPS-STD-7C.
- c. If sidewalk delivery is authorized, customers must erect sidewalk-mounted receptacles that comply with USPS-STD-7C.

The Postal Service annually publishes a list of USPS-approved mailbox equipment and approved manufacturers in its *Postal Bulletin*.

<http://about.usps.com/postal-bulletin/2017/pb22467/html/welcome.htm>

You can find the latest list of USPS-approved equipment and approved manufacturers at:

<http://about.usps.com/what-we-are-doing/current-initiatives/delivery-growth-management/welcome.htm>

8.2 Centralized Mail Receptacle Installation

You must consider many variables when installing centralized mailbox equipment. In addition to providing accessible locations, you must conduct proper foundation preparation and follow specific mounting procedures, to name a few requirements.

Appendices A through D of this guide provide sample diagrams of various CBU installations to help you understand space requirements, placement, etc.

Note: It is critical that you refer to the installation manuals furnished by each of the manufacturers for the specific USPS-approved centralized mailbox equipment purchased commercially.

For assistance with siting your outdoor centralized mail equipment, contact your local USPS Growth Manager so that the Postal Service can advise about the proper locations as you finalize plans for your new development.

9 Closing

Thank you for taking time to review this guide for planning mail delivery for new development.

We periodically update this guide—so be sure to check online for the latest version on the ABOUT.USPS.COM website at:

<http://about.usps.com/what-we-are-doing/current-initiatives/delivery-growth-management/welcome.htm>

Reminder: You can find the Growth Manager who covers your specific development geography by sending an email to: Delivery.Growth@USPS.GOV.

Or, you can contact your Post Office and ask to speak to the Postmaster or person assigned to assist developers with planning new mail service.

APPENDIX A – Cluster Box Unit Installation Single Unit

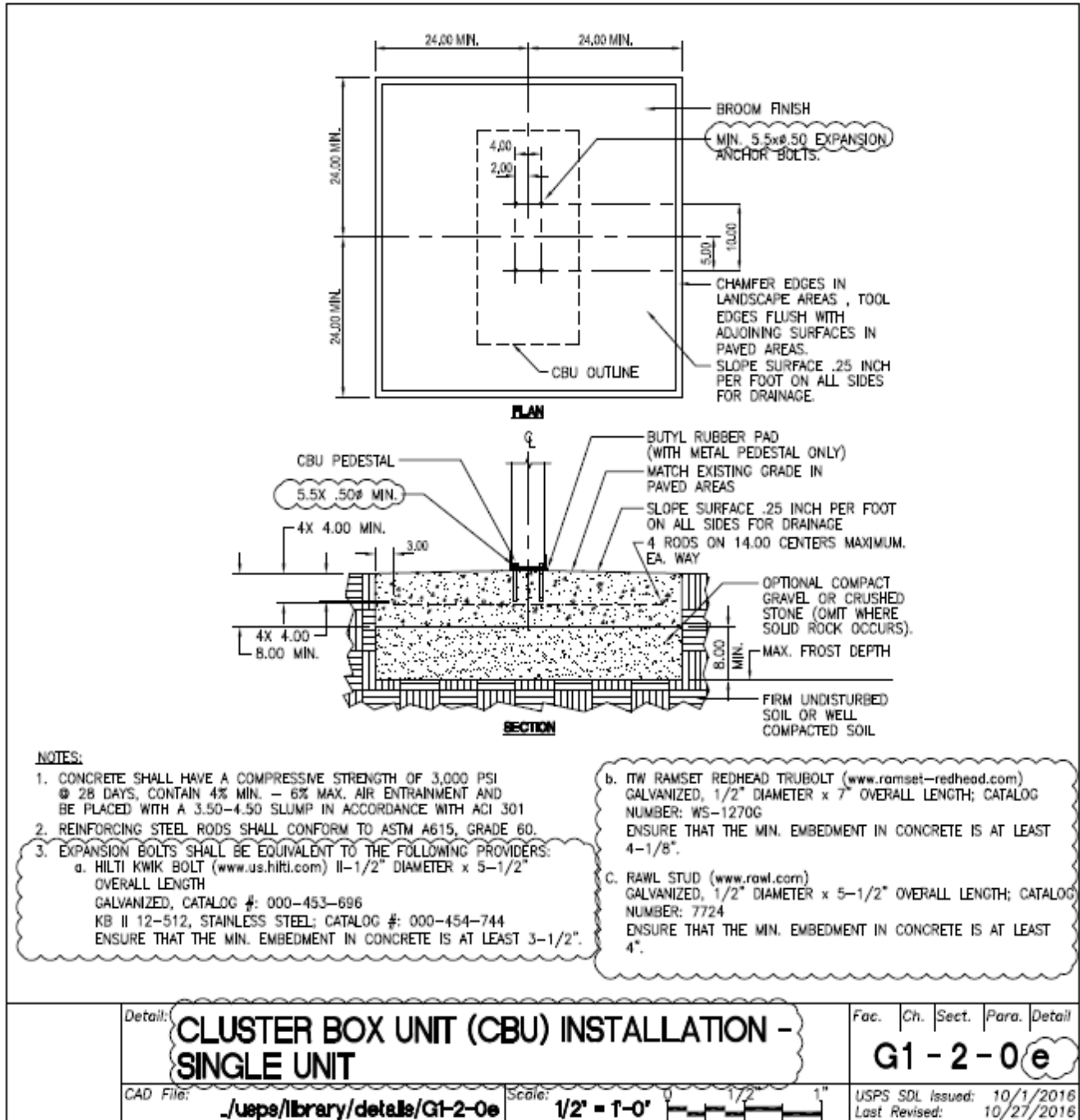

APPENDIX B – Cluster Box Unit Installation Multiple Unit

NOTES TO A/E:

PLAN

SECTION

NOTES:

- CONCRETE SHALL HAVE A COMPRESSIVE STRENGTH OF 3,000 PSI @ 28 DAYS, CONTAIN 4% MIN. - 6% MAX. AIR ENTRAINMENT AND BE PLACED WITH A 3.50 - 4.50 SLUMP IN ACCORDANCE WITH ACI 301
- REINFORCING STEEL RODS SHALL CONFORM TO ASTM A615, GRADE 60.
- EXPANSION BOLTS SHALL BE EQUIVALENT TO THE FOLLOWING PROVIDERS:
 - HILTI KWIK BOLT (www.us.hilti.com) 1/2" DIAMETER x 5-1/2" OVERALL LENGTH GALVANIZED, CATALOG # 000-453-896
KB 12-512, STAINLESS STEEL, CATALOG # 000-454-744
ENSURE THAT THE MIN. EMBEDMENT IN CONCRETE IS AT LEAST 3-1/2".
 - ITW RAMSET REDHEAD TRUBOLT (www.ramset-redhead.com) GALVANIZED, 1/2" DIAMETER x 7" OVERALL LENGTH; CATALOG NUMBER: WS-1270G
ENSURE THAT THE MIN. EMBEDMENT IN CONCRETE IS AT LEAST 4-1/8".
 - RAWL STUD (www.rawl.com) GALVANIZED, 1/2" DIAMETER x 5-1/2" OVERALL LENGTH; CATALOG NUMBER: 7724
ENSURE THAT THE MIN. EMBEDMENT IN CONCRETE IS AT LEAST 4".
- A 3 CBU CONFIGURATION IS DEPICTED. A 2 OR 4 CBU CONFIGURATION MAY BE USED AS LONG AS THEY ARE ARRANGED IN GROUPS SUCH THAT THE OVERALL DIMENSION OF THE CONCRETE BASE DOES NOT EXCEED 16 FEET.

Detail:	CLUSTER BOX UNIT (CBU) INSTALLATION - MULTIPLE UNIT	Fac.	Ch.	Sect.	Para.	Detail
		G1-2-0 e1				
CAD File:	./usps/library/details/G1-2-0e1	Scale:	1/2" = 1'-0"		USPS SDL Issued:	10/1/2016
					Last Revised:	10/27/2016

APPENDIX C – Cluster Box Unit Access Maneuvering Space – Single Unit

NOTES TO A/E:

- IF THE ACCESSIBLE ROUTE FROM THE CBU(S) CONNECTS WITH A STREET OR OTHER PAVED SURFACE AT A VERTICAL CURB, A CURB RAMP SHOULD BE INSTALLED IN ACCORDANCE WITH RE-4 REQUIREMENTS.

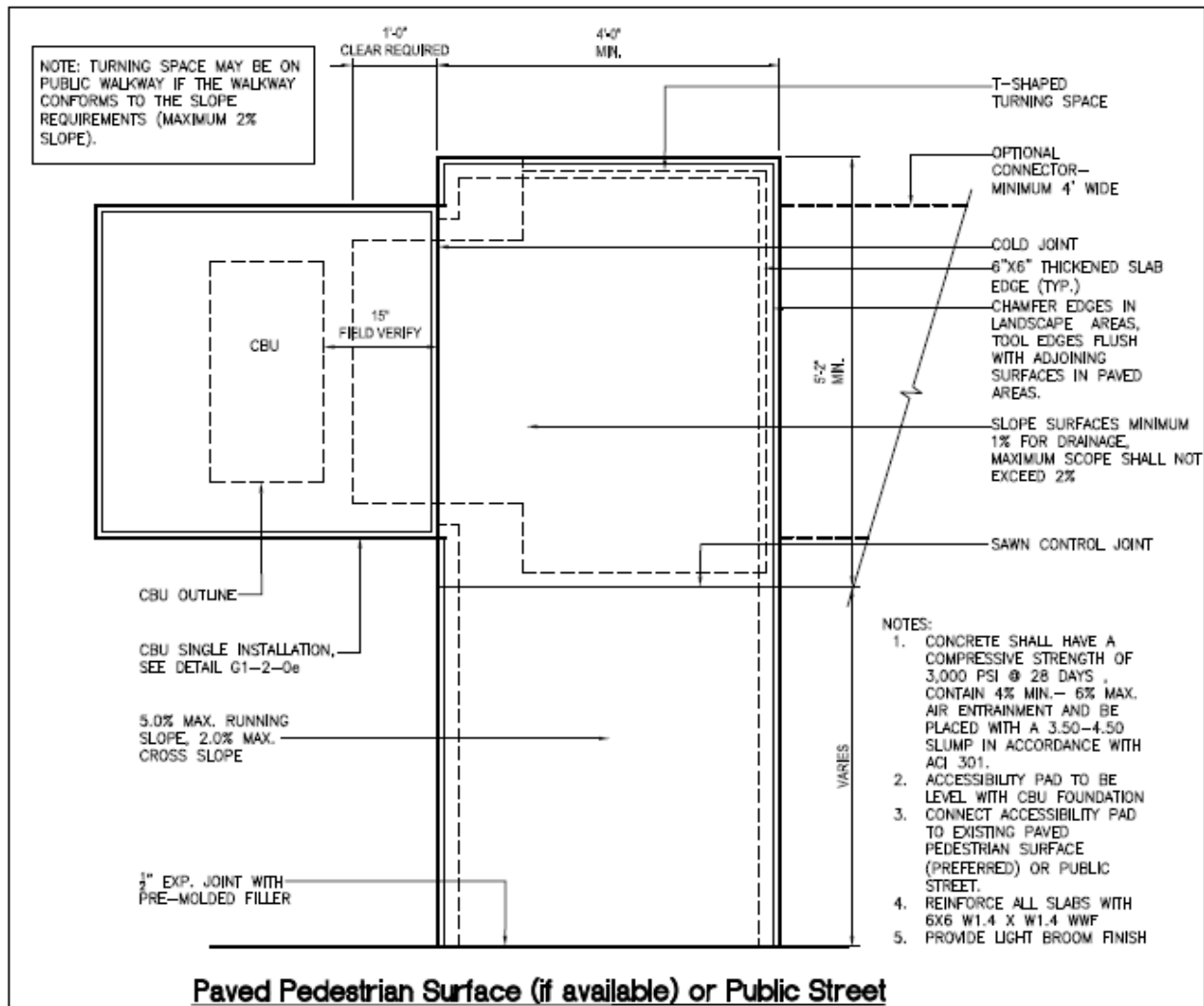

Detail:	CLUSTER BOX UNIT (CBU) ACCESS MANEUVERING SPACE - SINGLE UNIT	Fac.	Ch.	Sect.	Para.	Detail
						G1-2-0e2
CAD File:	.\usps\library\details\G1-2-0e2.dwg	Scale:	1/2" = 1'-0"			
				USPS SDL issued: 10/1/2016 Last Revised: 7/14/2016		

APPENDIX D – Cluster Box Unit Access Maneuvering Space – Single Unit

NOTES TO A/E:

- IF THE ACCESSIBLE ROUTE FROM THE CBU(S) CONNECTS WITH A STREET OR OTHER PAVED SURFACE AT A VERTICAL CURB, A CURB RAMP SHOULD BE INSTALLED IN ACCORDANCE WITH RE-4 REQUIREMENTS.

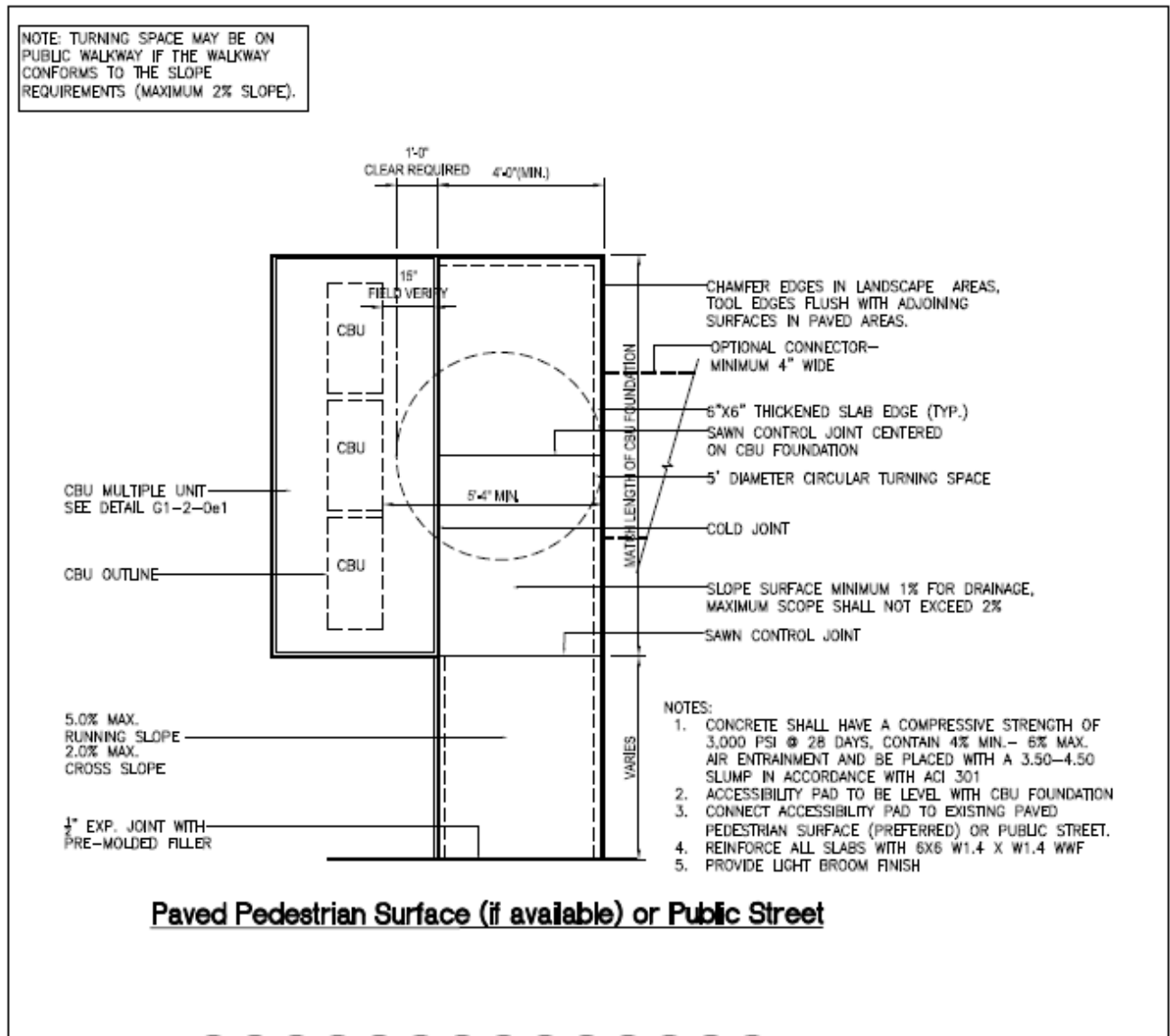

Detail:	CLUSTER BOX UNIT (CBU) ACCESS MANEUVERING SPACE - MULTIPLE UNIT	Fac.	Ch.	Sec.	Para.	Detail
						G1-2-0 e3
CAD File:	..(usps\library\details\G1-2-0e3.dwg)	Scale:	1/4"=1'-0"	0	1/2"	1"
						USPS SDL Issued: 10/1/2016 Last Revised: 7/14/2016

Centralized Mail Delivery Residential Applications

Another Concept in Delivery Service

Publication 265-A
October 2017



UNITED STATES
POSTAL SERVICE®

Centralized Mail Delivery Residential Applications

Centralized Mail Delivery provides delivery and collection services for a number of residences from a convenient, centrally located installation.

Benefits to developers, builders, and owners who use Centralized Mail Delivery in innovative installations, such as the ones depicted in this publication, include:

Increased Security

Centralized Mail Delivery installations are less isolated and more visible to others.

Other Advantages

Customer compartments in Centralized Mail Delivery equipment may be large enough to accommodate several days' accumulation of mail, eliminating the need to have mail held at the Post Office™ during short periods away from home.

Centralized Installations

Types

A **Neighborhood Delivery Center** is a freestanding, sheltered or enclosed installation containing a large number of individually locked, wall-mounted mailboxes.

A **Cluster Box Unit (CBU)** is a freestanding, pedestal-mounted mailbox containing 8, 12, 13, or 16 individually locked mailboxes and parcel compartments.

Manufacturers can modify installations to blend with any community décor.



Planning

The Postal Service prefers to establish the most efficient mode of delivery in new residential developments, including



the determination of the type and location of mail delivery receptacles and collection boxes. During a new residential development's design and planning phase (i.e., before the developers and builders finalize plans and site plats with the appropriate planning/zoning authorities), developers and builders must notify the Postal Service. Then, the Postal Service will consider input from these parties. Developers and builders should plan

for basic or customized Centralized Mail Delivery Installations for residential communities (i.e., Neighborhood Delivery Centers or CBU's).

For more information on Centralized Mail Delivery, contact your local Post Office or visit **<http://about.usps.com/what-we-are-doing/current-initiatives/delivery-growth-management/welcome.htm>**.

Publication 265-A, October 2017
PSN 7610-03-000-3573

